

Operating Temperature: 0°C~70°C
 Operating Humidity: 20%~80% (no condensation)
 Storage Temperature: -25°C~85°C
 Storage Humidity: 20%~80% (no condensation)

L:
 CBL-32USPD302MBS-0.5m 500mm±10mm
 CBL-32USPD302MBS-1m 1000mm±10mm
 CBL-32USPD302MBS-1.5m 1500mm±20mm
 CBL-32USPD302MBS-2m 2000mm±20mm

PIN OUT

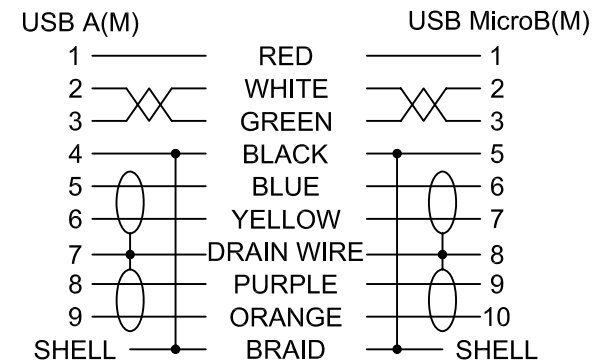

No	MATERIALS LIST:
1.	CABLE:UL2725 (34AWG*1PR+D+AL+M)x2C+32AWG*1PR+30AWG*1C+AL+B OD:3.2mm PVC JACKET COLOR:BLACK
2.	CONNECTOR:USB 3.0 A/M, 9P, BLUE INSULATOR SOLDER TYPE, NICKEL PLATED SHELL
3.	CONNECTOR:USB 3.0 MicroB/M, 10P, BLACK INSULATOR SOLDER TYPE, NICKEL PLATED SHELL
4.	ABS ASSEMBLY HOUSING,BLACK COLOR
5.	SCREW:#3x20.7 M2

Jargy part no.	Client part no.	Approved	SCALE	UNIT
CBL-32USPD302MBS-Xm				mm
Drawing Name		Drawn	Date	REV.
USB 3.0 A to Micro-B Cable M/M				1.0

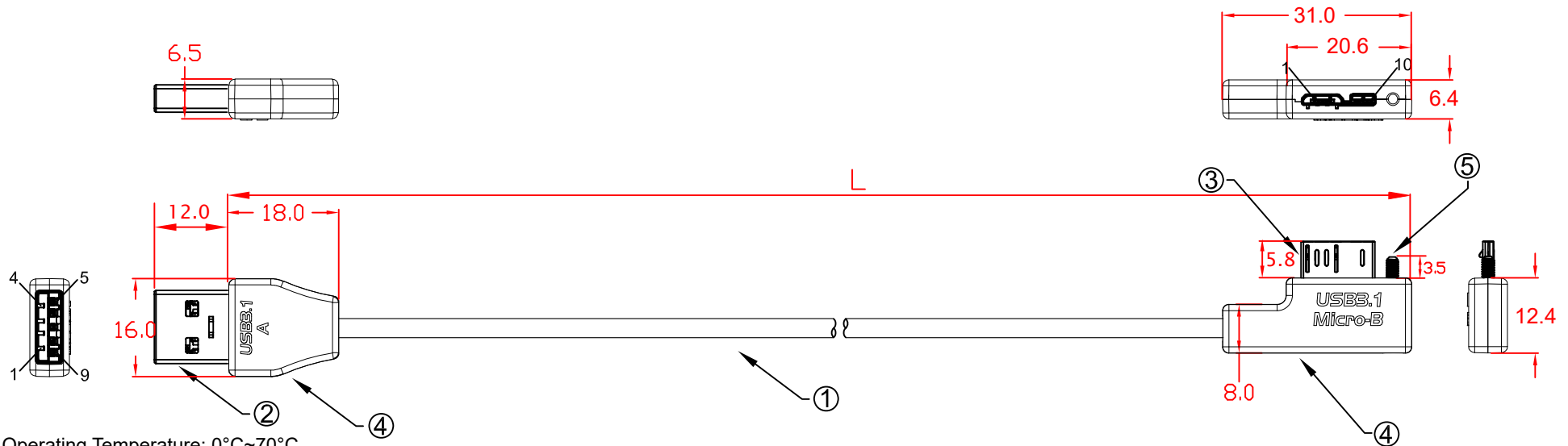

Operating Temperature: 0°C~70°C
 Operating Humidity: 20%~80% (no condensation)
 Storage Temperature: -25°C~85°C
 Storage Humidity: 20%~80% (no condensation)

L:
 CBL-32USPD302MBL-0.5mLA 500mm±10mm
 CBL-32USPD302MBL-1mLA 1000mm±10mm
 CBL-32USPD302MBL-1.5mLA 1500mm±20mm
 CBL-32USPD302MBL-2mLA 2000mm±20mm

PIN OUT

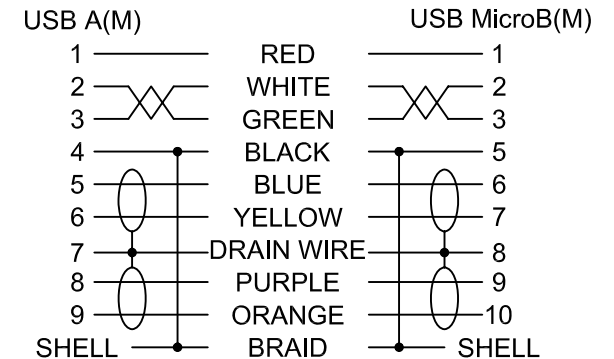

No	MATERIALS LIST:
1.	CABLE:UL2725 (34AWG*1PR+D+AL+M)x2C+32AWG*1PR+30AWG*1C+AL+B OD:3.2mm PVC JACKET COLOR:BLACK
2.	CONNECTOR:USB 3.0 A/M, 9P, BLUE INSULATOR SOLDER TYPE, NICKEL PLATED SHELL
3.	CONNECTOR:USB 3.0 MicroB/M, 10P, BLACK INSULATOR SOLDER TYPE, NICKEL PLATED SHELL
4.	ABS ASSEMBLY HOUSING, BLACK COLOR
5.	SCREW:#3x15.8 M2

Jargy part no.	Client part no.	Approved	SCALE	UNIT
CBL-32USPD302MBL-XmLA				mm
Drawing Name		Drawn	Date	REV.
USB 3.0 A to Micro-B Cable M/M				1.0

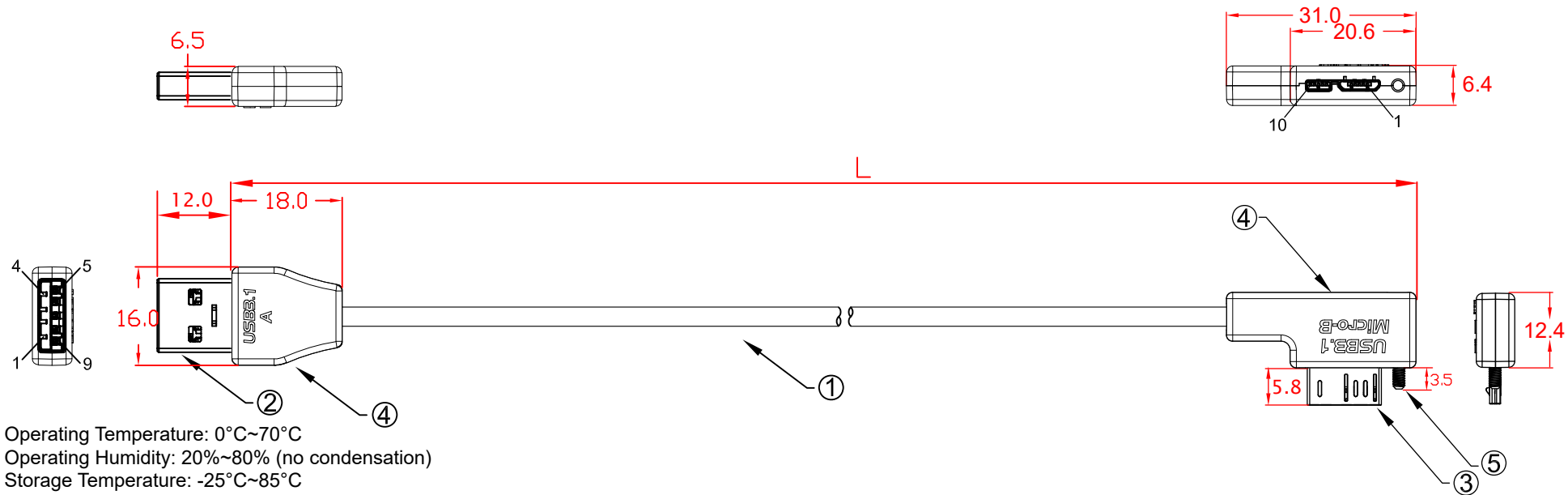

Operating Temperature: 0°C~70°C
 Operating Humidity: 20%~80% (no condensation)
 Storage Temperature: -25°C~85°C
 Storage Humidity: 20%~80% (no condensation)

L:

CBL-32USPD302MBL-0.5mRA	500mm±10mm
CBL-32USPD302MBL-1mRA	1000mm±10mm
CBL-32USPD302MBL-1.5mRA	1500mm±20mm
CBL-32USPD302MBL-2mRA	2000mm±20mm

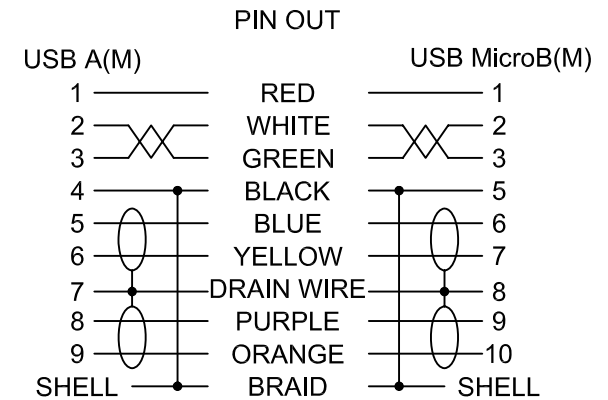

No	MATERIALS LIST:
1.	CABLE:UL2725 (34AWG*1PR+D+AL+M)x2C+32AWG*1PR+30AWG*1C+AL+B OD:3.2mm PVC JACKET COLOR:BLACK
2.	CONNECTOR:USB 3.0 A/M, 9P, BLUE INSULATOR SOLDER TYPE, NICKEL PLATED SHELL
3.	CONNECTOR:USB 3.0 MicroB/M, 10P, BLACK INSULATOR SOLDER TYPE, NICKEL PLATED SHELL
4.	ABS ASSEMBLY HOUSING, BLACK COLOR
5.	SCREW:#3x15.8 M2

Jargy part no.	Client part no.	Approved	SCALE	UNIT
CBL-32USPD302MBL-XmRA				mm
Drawing Name		Drawn	Date	REV.
USB 3.0 A to Micro-B Cable M/M				1.0

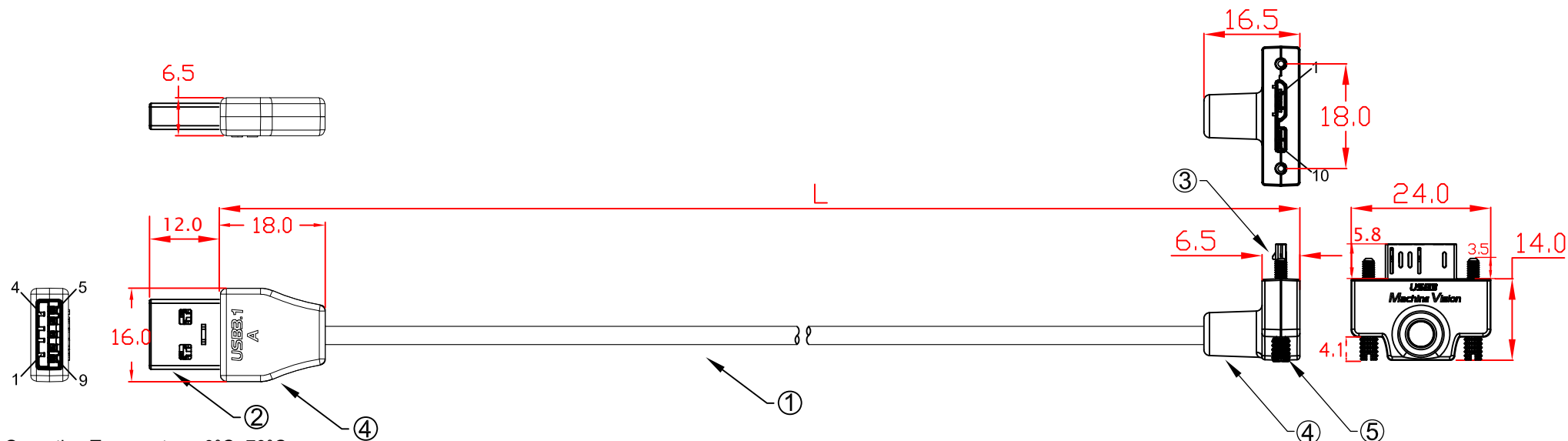

Operating Temperature: 0°C~70°C
 Operating Humidity: 20%~80% (no condensation)
 Storage Temperature: -25°C~85°C
 Storage Humidity: 20%~80% (no condensation)

L:
 CBL-32USPD302MBH-0.5mUA 500mm±10mm
 CBL-32USPD302MBH-1mUA 1000mm±10mm
 CBL-32USPD302MBH-1.5mUA 1500mm±20mm
 CBL-32USPD302MBH-2mUA 2000mm±20mm

PIN OUT

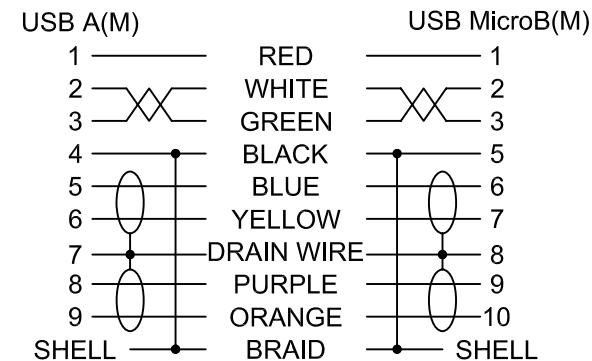

No	MATERIALS LIST:
1.	CABLE:UL2725 (34AWG*1PR+D+AL+M)x2C+32AWG*1PR+30AWG*1C+AL+B OD:3.2mm PVC JACKET COLOR:BLACK
2.	CONNECTOR:USB 3.0 A/M, 9P, BLUE INSULATOR SOLDER TYPE, NICKEL PLATED SHELL
3.	CONNECTOR:USB 3.0 MicroB/M, 10P, BLACK INSULATOR SOLDER TYPE, NICKEL PLATED SHELL
4.	ABS ASSEMBLY HOUSING, BLACK COLOR
5.	SCREW:#3x17.7 M2

Jargy part no.	Client part no.	Approved	SCALE	UNIT
CBL-32USPD302MBH-XmUA				mm
Drawing Name		Drawn	Date	REV.
USB 3.0 A to Micro-B Cable M/M				1.0

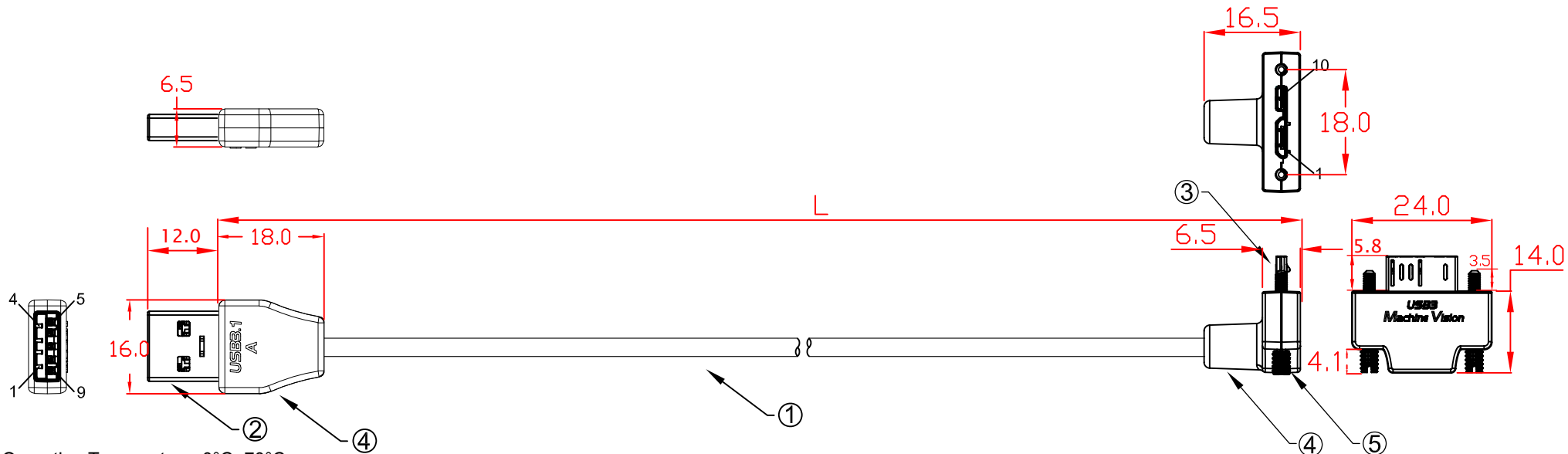

Operating Temperature: 0°C~70°C
 Operating Humidity: 20%~80% (no condensation)
 Storage Temperature: -25°C~85°C
 Storage Humidity: 20%~80% (no condensation)

L:

CBL-32USPD302MBH-0.5mDA	500mm±10mm
CBL-32USPD302MBH-1mDA	1000mm±10mm
CBL-32USPD302MBH-1.5mDA	1500mm±20mm
CBL-32USPD302MBH-2mDA	2000mm±20mm

No	MATERIALS LIST:
1.	CABLE:UL2725 (34AWG*1PR+D+AL+M)x2C+32AWG*1PR+30AWG*1C+AL+B OD:3.2mm PVC JACKET COLOR:BLACK
2.	CONNECTOR:USB 3.0 A/M, 9P, BLUE INSULATOR SOLDER TYPE, NICKEL PLATED SHELL
3.	CONNECTOR:USB 3.0 MicroB/M, 10P, BLACK INSULATOR SOLDER TYPE, NICKEL PLATED SHELL
4.	ABS ASSEMBLY HOUSING, BLACK COLOR
5.	SCREW:#3x17.7 M2

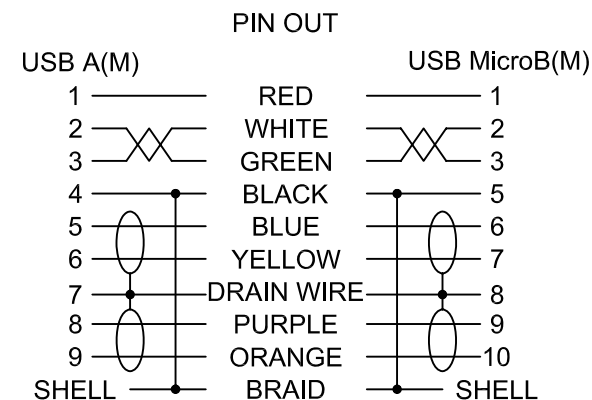

Jargy part no.	Client part no.	Approved	SCALE	UNIT
CBL-32USPD302MBH-XmDA				mm
Drawing Name		Drawn	Date	REV.
USB 3.0 A to Micro-B Cable M/M				1.0